

**T-1 3/4 PACKAGE**  
**SOLID STATE LAMP**

**MVL-514SW-T**

**Description**

The MVL-514SW-T a white source color device, is made with InGaN on Sapphire substrate LED die. T-1 3/4 (5mm) water clear plastic lens package.

**Package Dimensions**

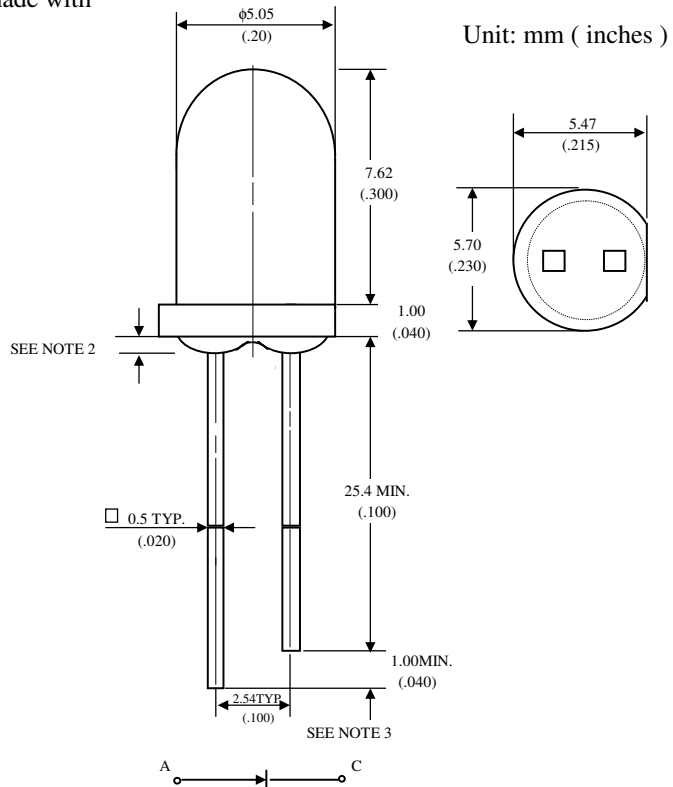

Notes :

1. Tolerance is  $\pm 0.25$  mm (.010") unless otherwise noted.
2. Protruded resin under flange is 0.8 mm (.031") max.
3. Lead spacing is measured where the leads emerge from the package.

**Absolute Maximum Ratings**

@  $T_A=25^\circ\text{C}$

Parameter	Symbol	Maximum Rating	Unit
Peak Forward Current(1/10 Duty Cycle@1KHz )	$I_{pf}$	100	mA
Continuous Forward Current	$I_{af}$	30	mA
Reverse Voltage	$V_R$	5	V
Operating Temperature Range	$T_{opr}$	-20°C to +80°C	
Storage Temperature Range	$T_{stg}$	-30°C to +100°C	
Solder temperature 1.6 mm from body for 3 seconds at 260°C			

Notes: 1. Product resistance to electrostatic discharge (ESD) is measured by simulating ESD using a rapid avalanche energy test (RAET). The RAET procedures are designed to approximate the maximum ESD ratings shown. Seller gives no other assurances regarding the ability of products to withstand ESD.

## Optical-Electrical Characteristics

@  $T_A=25^\circ\text{C}$

Parameter	Test Conditions	Symbol	Min .	Typ .	Max .	Unit .
Luminous Intensity	$I_F=20\text{mA}$	$I_V$	9000	11000		mcd
Forward Voltage	$I_F=20\text{mA}$	$V_F$	-	3.2	4.0	V
Reverse Current	$V_R=5\text{V}$	$I_R$	-	-	100	$\mu\text{A}$
Viewing Angle	$I_F=20\text{mA}$	$2\theta_{1/2}$	-	15	-	deg.
C.I.E. 1931	$I_F=20\text{mA}$	x	-	0.31	-	-
Chromaticity Coordinates		y	-	0.32	-	-

## Typical Optical-Electrical Characteristic Curves

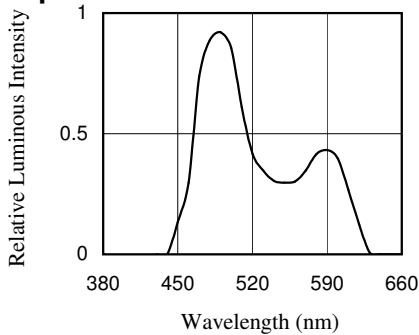

FIG.1 RELATIVE LUMINOUS INTENSITY VS. WAVELENGTH

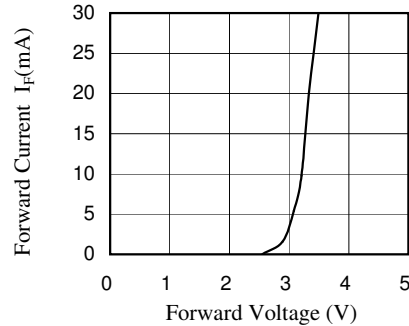

FIG.2 FORWARD CURRENT VS. FORWARD VOLTAGE

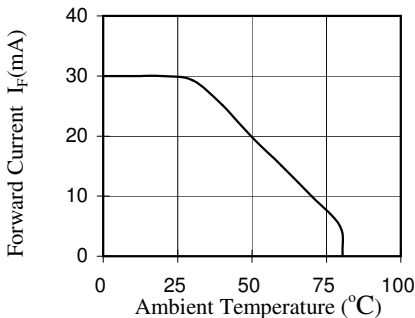

FIG.3 FORWARD CURRENT VS. AMBIENT TEMPERATURE

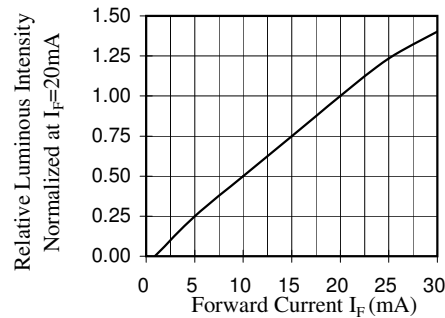

FIG.4 RELATIVE LUMINOUS INTENSITY VS. FORWARD CURRENT

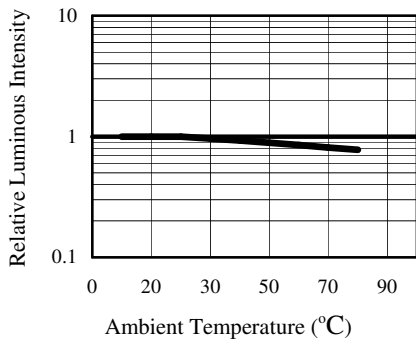

FIG.5 RELATIVE LUMINOUS INTENSITY VS. AMBIENT TEMPERATURE

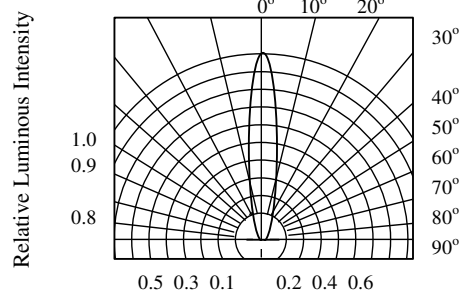

FIG.6 RADIATION DIAGRAM